

46622930

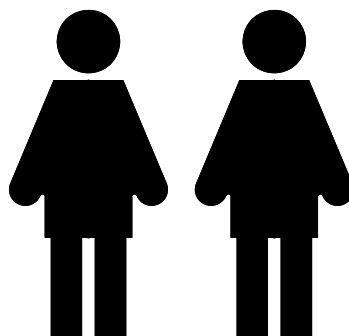
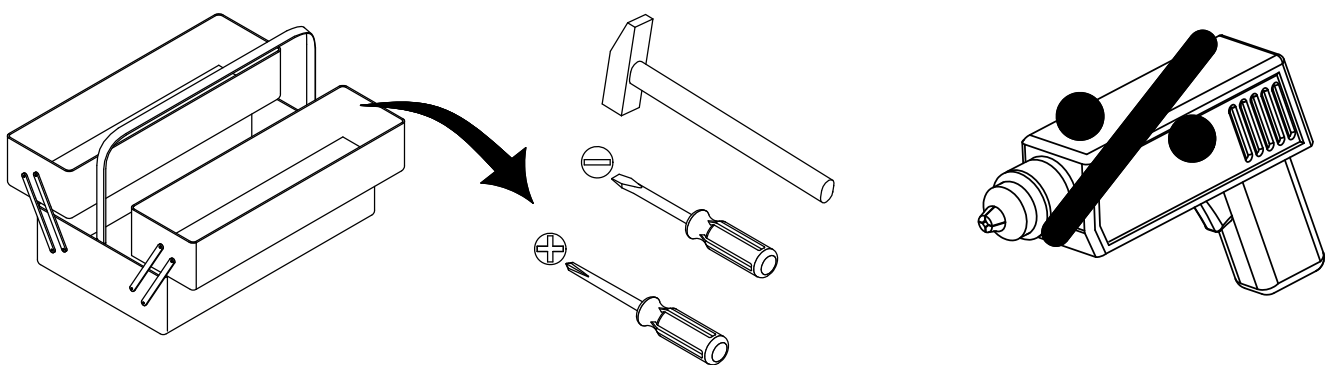
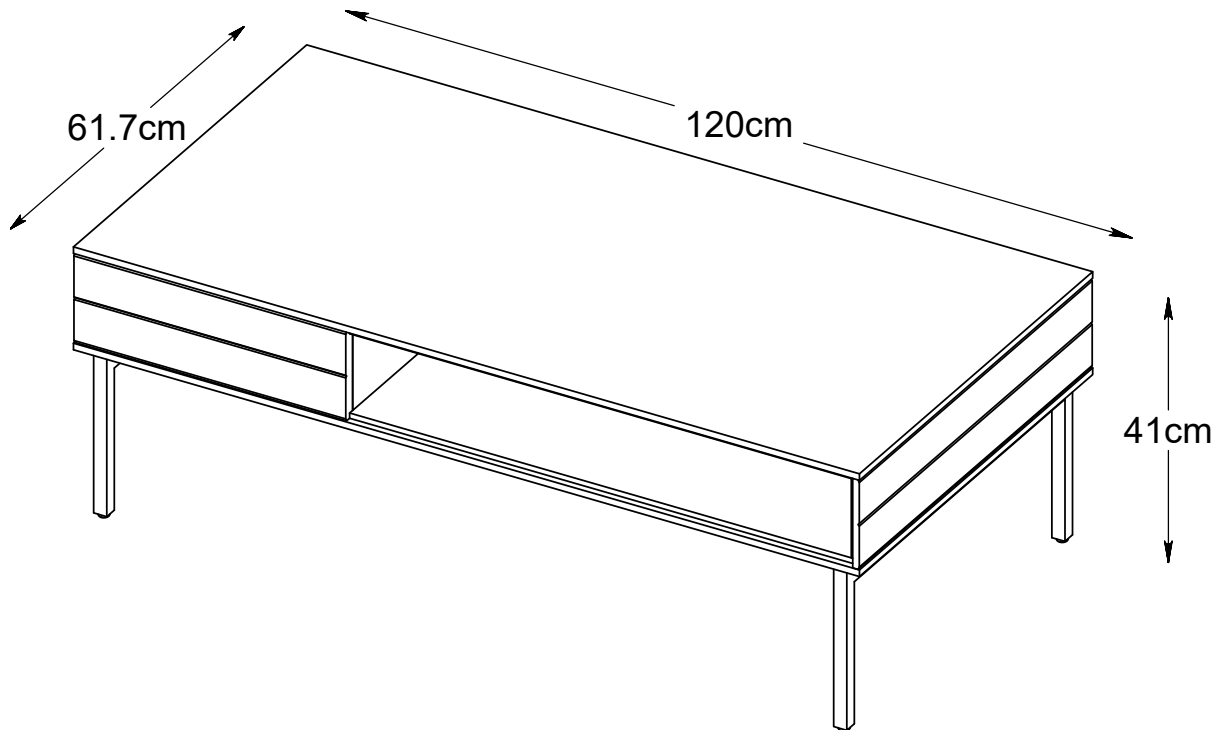

WICHTIG - FÜR SPÄTERE VERWENDUNG  
AUFBEWAHREN - SORGFÄLTIG LESEN

AVIS - Ces instructions doivent être sauvegardées  
Pour utilisation future - Les instructions doivent  
être suivies

IMPORTANTE, conservar estas instrucciones  
para futuro uso. Siga estas instrucciones atentamente

VIGTIGT - Samvejledningen skal opbevares  
i arkiv til senere brug - Skal gennemlæses nøje

NOTICE - These instructions must be saved  
for future use - Instructions must be followed



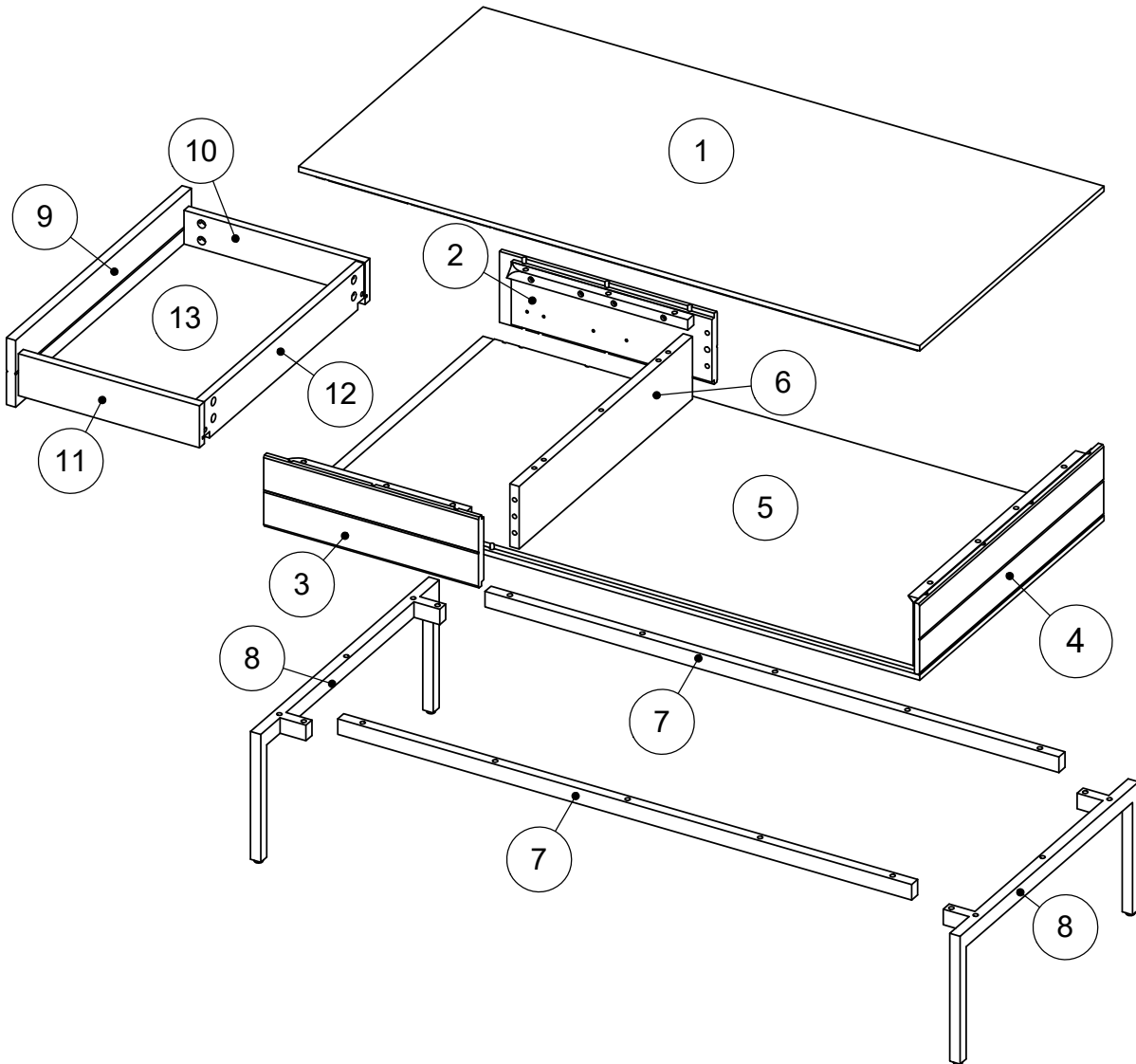

TEILCHECKLISTE  
 LISTE DE CONTROLE  
 LISTADO DE CONTROL  
 TJEKLISTE  
 CHECK LIST

Ref./No.	Ref./Art.	Qty./Stck./Quantité	Size / Maß / Dimension (mm)	Qty./Stck./Quantité	✓
1	329506293	1	1200x617x18		
2	329507293	1	415x137x38		
3	329508293	1	415x137x38		
4	329509293	1	616x137x38		
5	329510293	1	1200x617x18		
6	329511293	1	580x121x18		
7	229512	2	1109x30x20		
8	229513	2	597x253x70		
9	329336293	1	588x129x18		
10	329337293	1	350x81x16		
11	329338293	1	350x81x16		
12	329339293	1	538x79x16		
13	329340293	1	548x342x3		

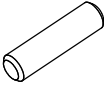
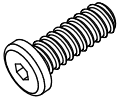
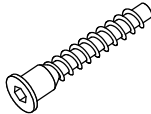
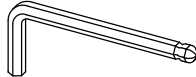

TEILCHECKLISTE - LISTE DE CONTROLE - LISTADO DE CONTROL- TJEKLISTE - CHECK LIST

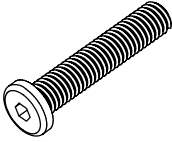
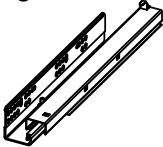
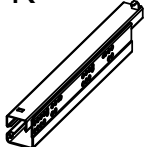
Réf./No.	Réf./Art.	Qty./Stck./Quantité	✓
A	229514	22	
B	229514	10	
C	229514	13	
D	229514	1	
E	229514	13	
F	229514	13	
G	229514	20	
J	229286	1	
K	229286	1	
L	229286	8	
W	229514	4	

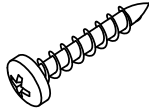
<p>22 - A</p>  <p>Ø8x40mm</p>	<p>10 - B</p>  <p>M6x30mm</p>	<p>13 - C</p>  <p>Ø7x50mm</p>	<p>1 - D</p>  <p>75x25x4mm</p>	<p>13 - E</p>  <p>Ø10x43mm</p>	<p>13 - F</p>  <p>Ø15x11mm</p>
<p>20 - G</p>  <p>M6x40mm</p>	<p>1 - J</p>  <p>350mm</p>	<p>1 - K</p>  <p>350mm</p>	<p>8 - L</p>  <p>Ø6x11mm</p>	<p>4 - W</p>  <p>Ø3.5x20mm</p>	

Geehrter Kunde.  
Hier haben Sie die Möglichkeit die mitgelieferten  
Schrauben nachzumessen.

Cher Client.  
La règle ci jointe vous permet de mesurer la visserie.

Estimado cliente.  
aquí podrá medir la tornillería adjunta.

Kære kunde.  
Her har De muligheden for at måle medsendte beslag.

Dear Customer.  
Below you have the opportunity to measure the  
Enclosed Hardware.

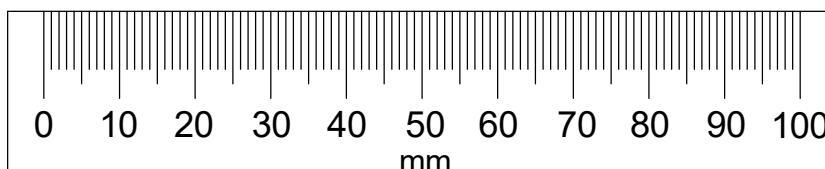

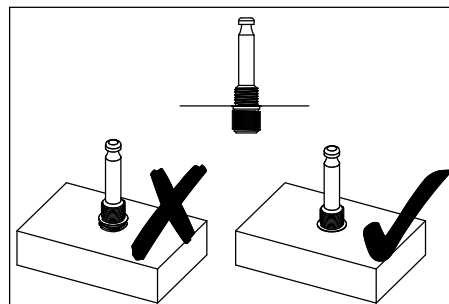
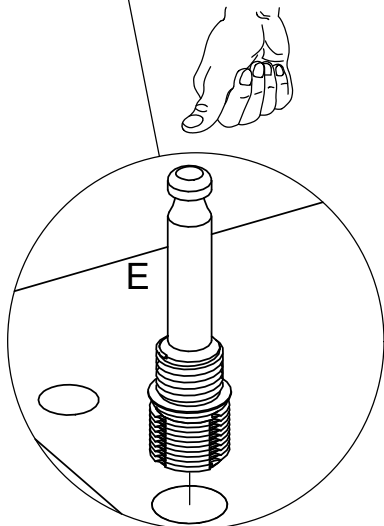
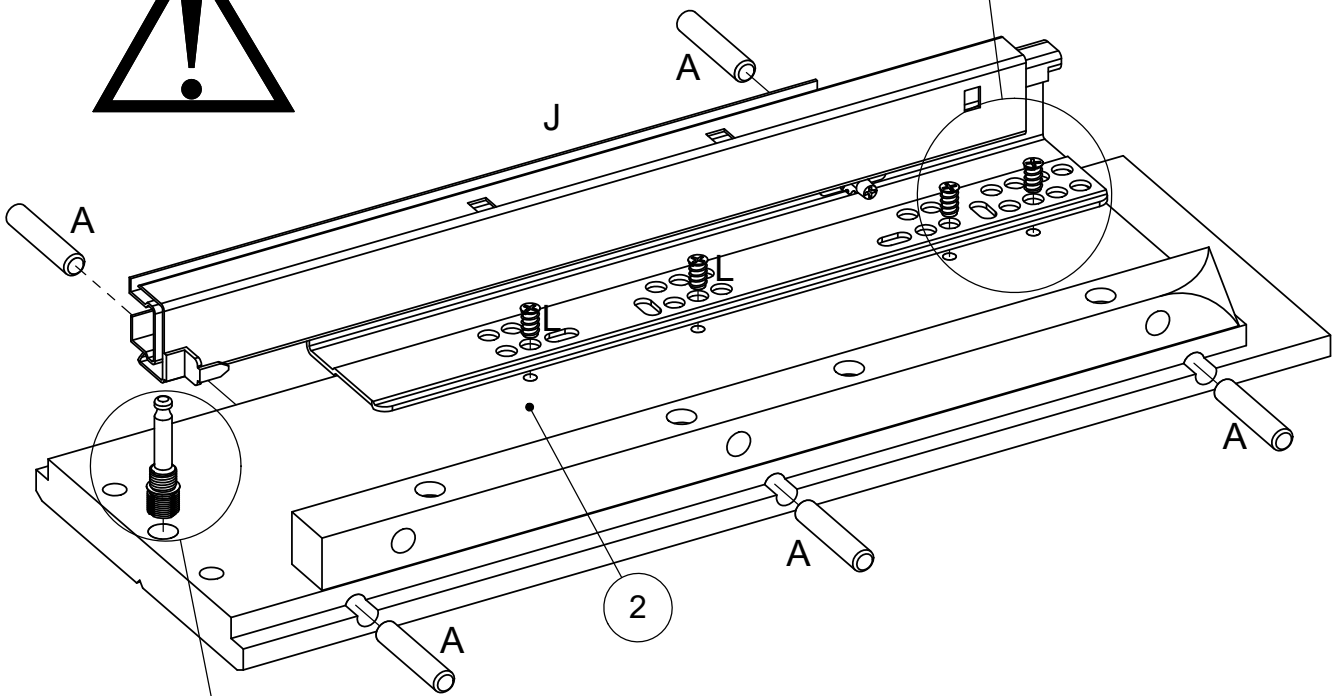
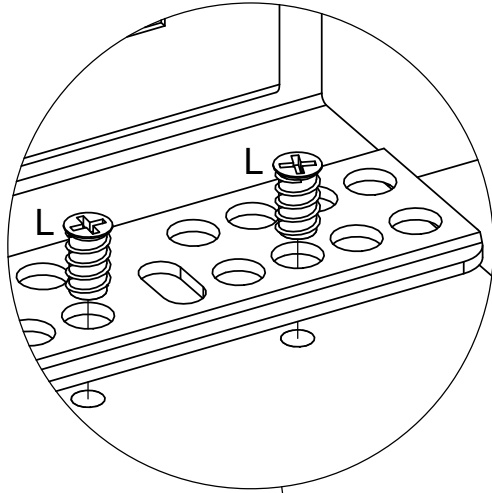
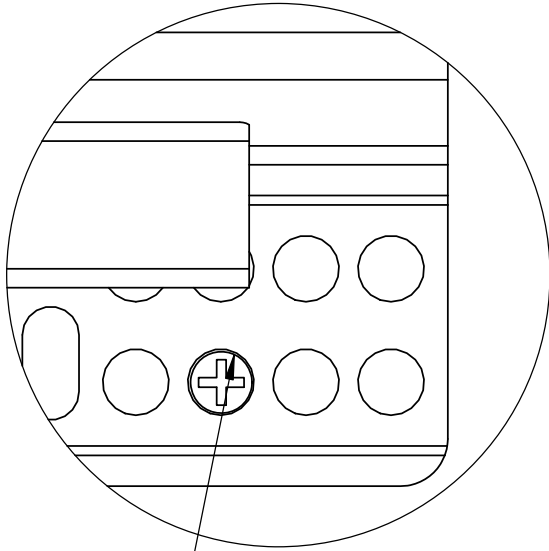
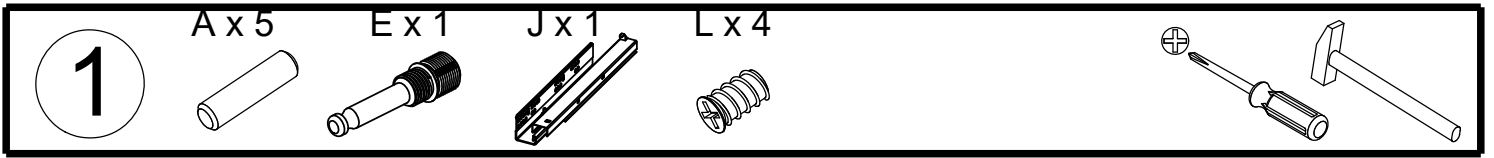

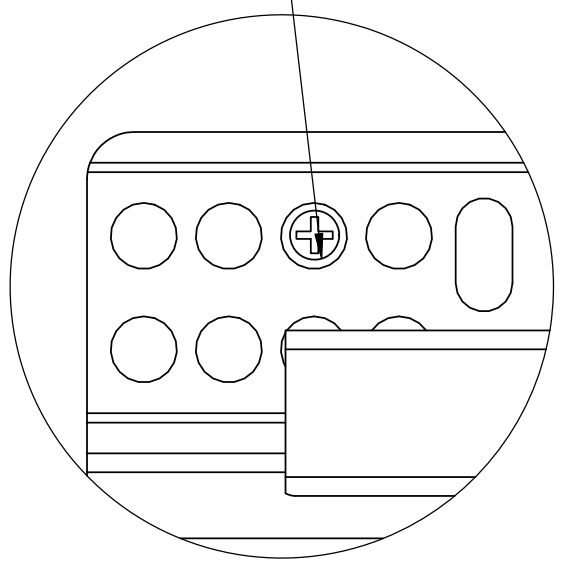
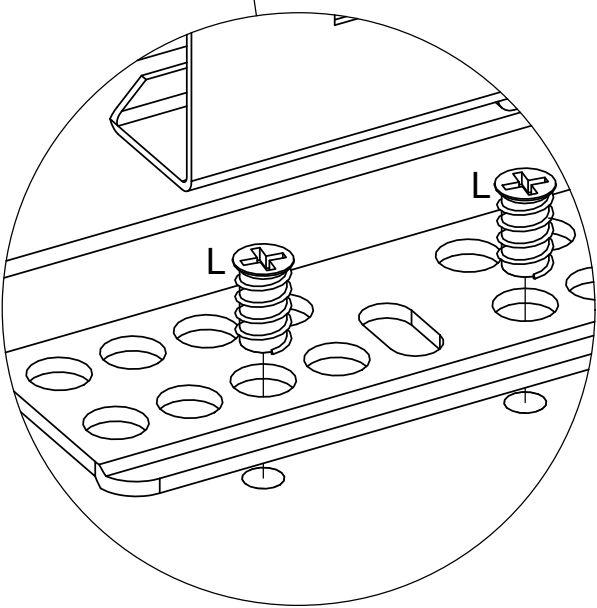
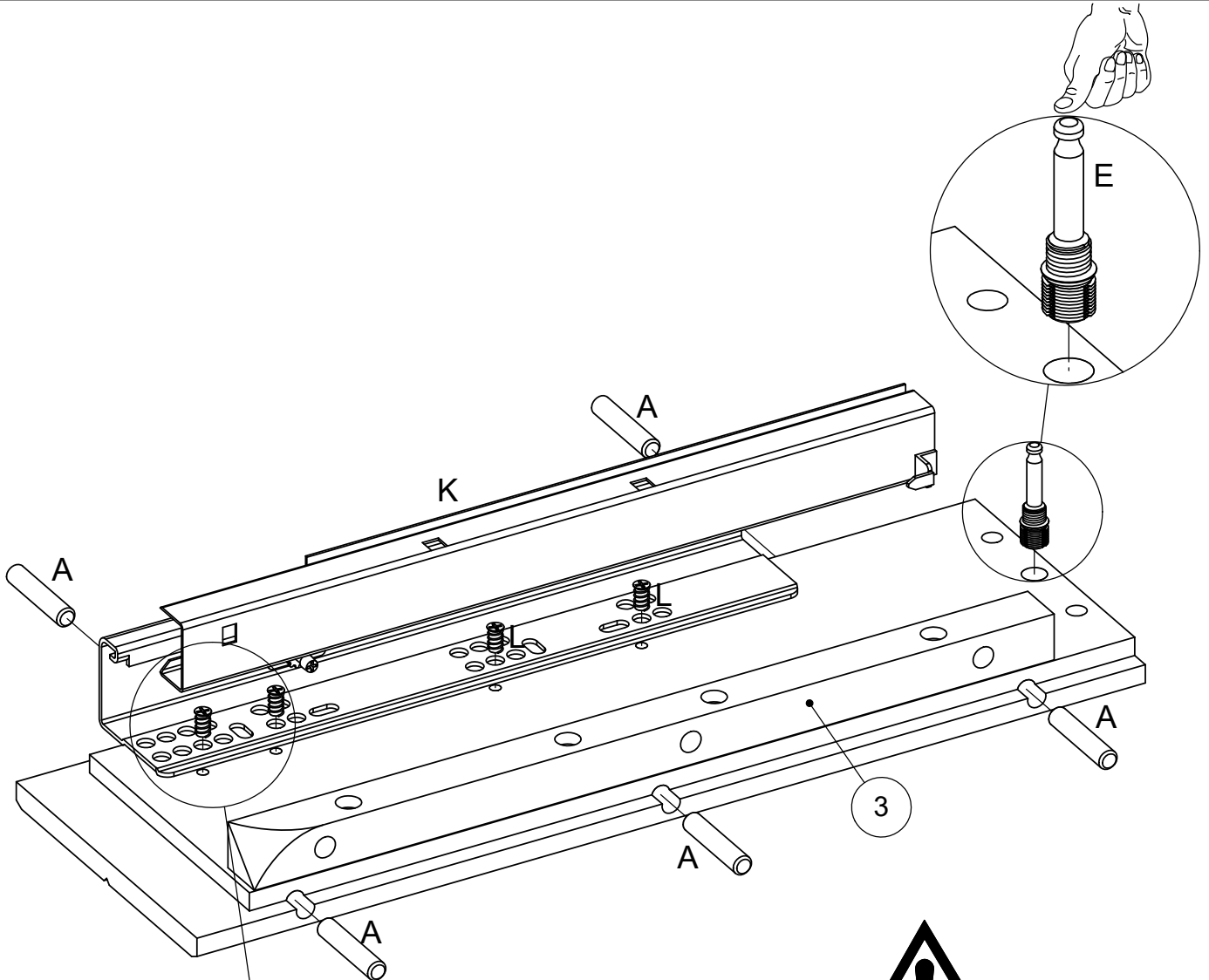
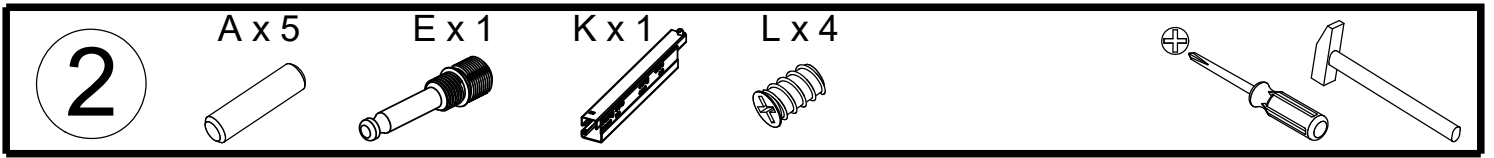

**3** A x 6  

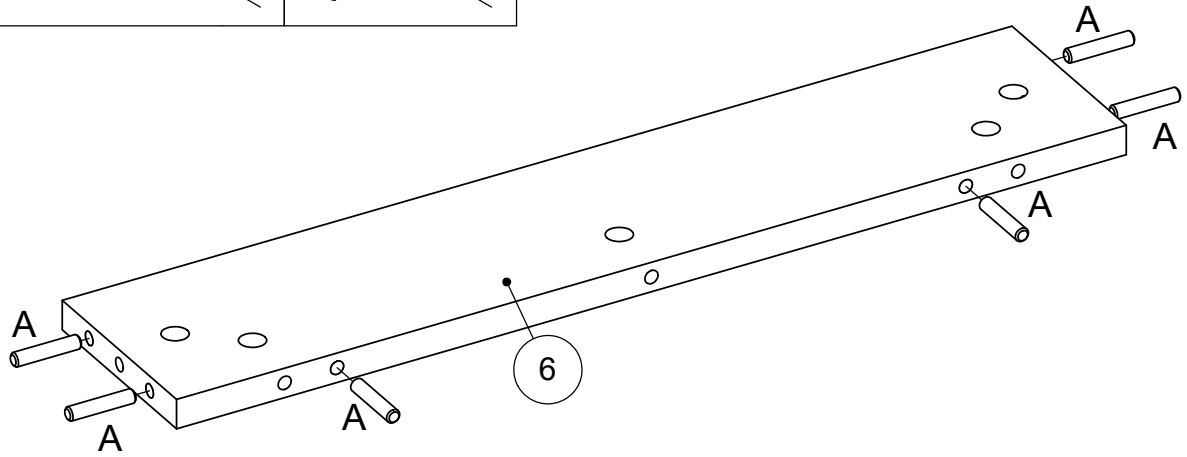
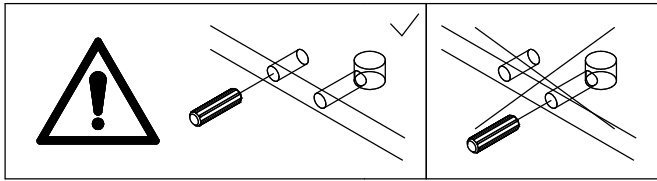

**4** F x 2  

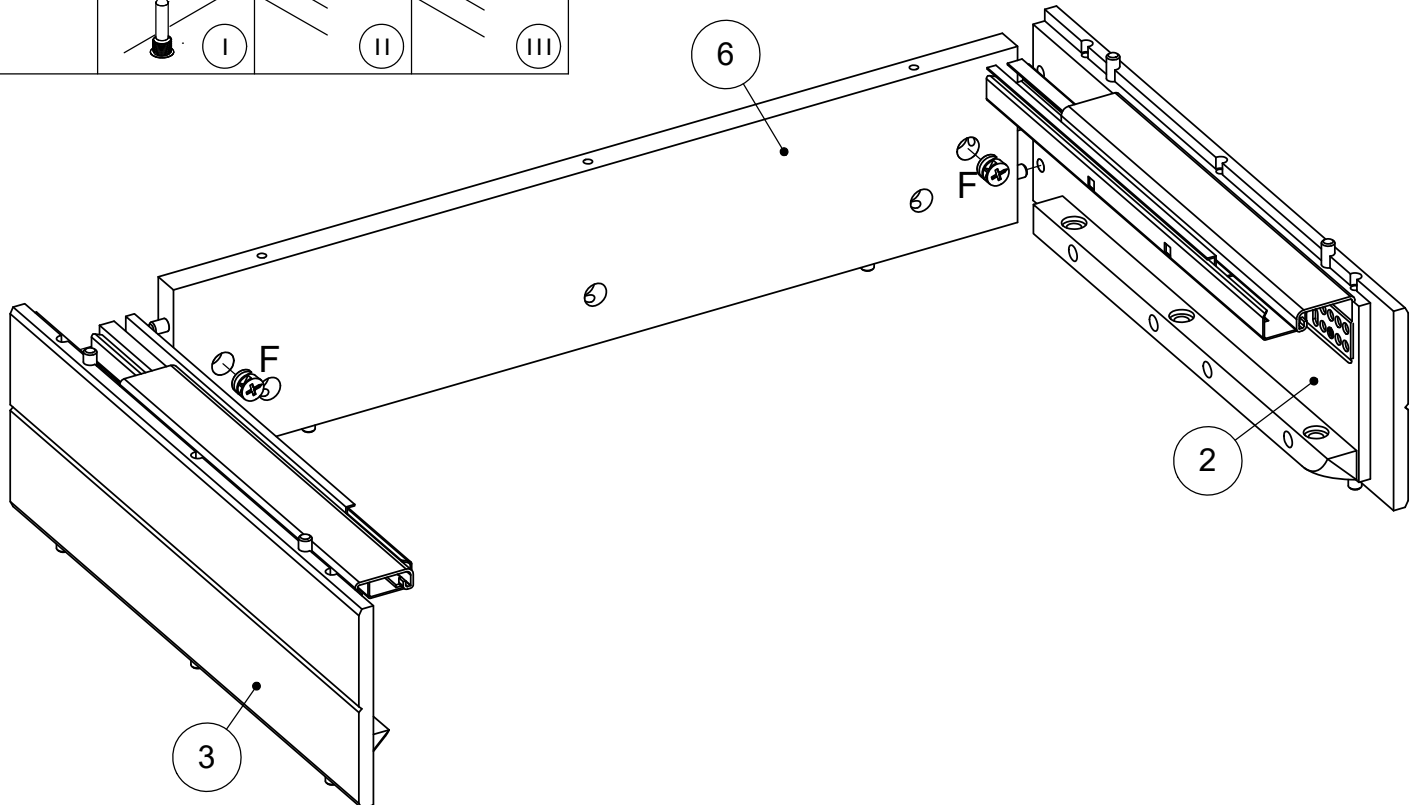
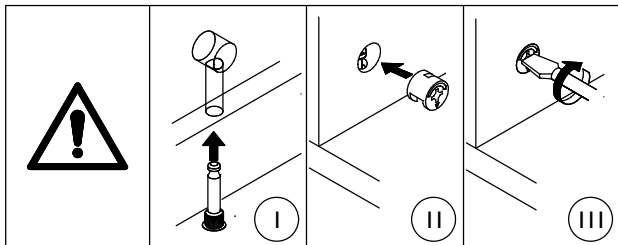

**5** Ex 3

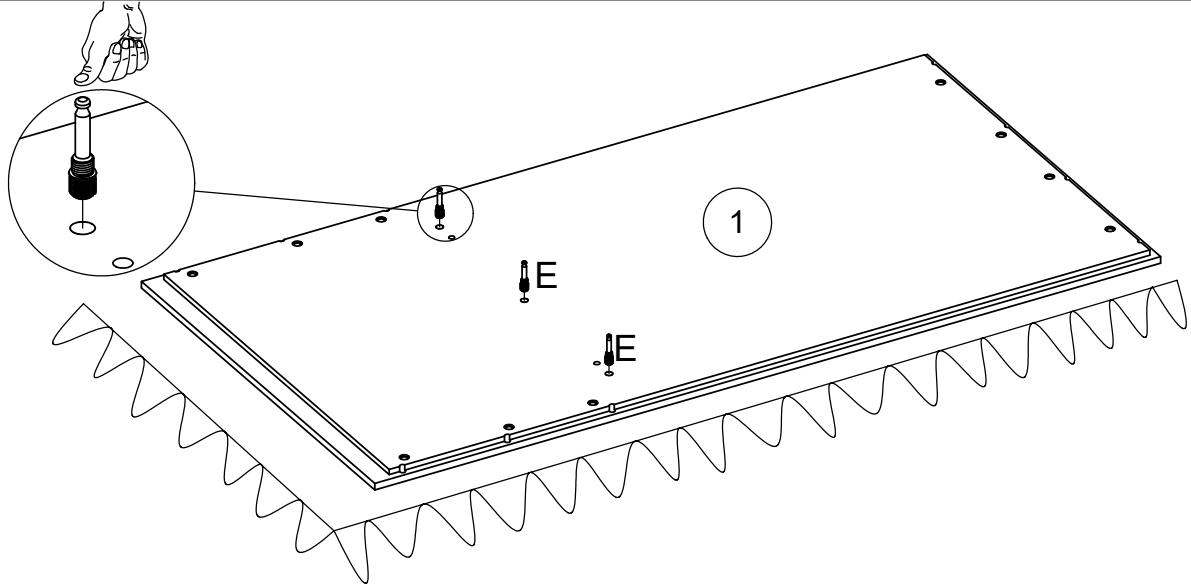

**6** B x 6 F x 3 D x 1

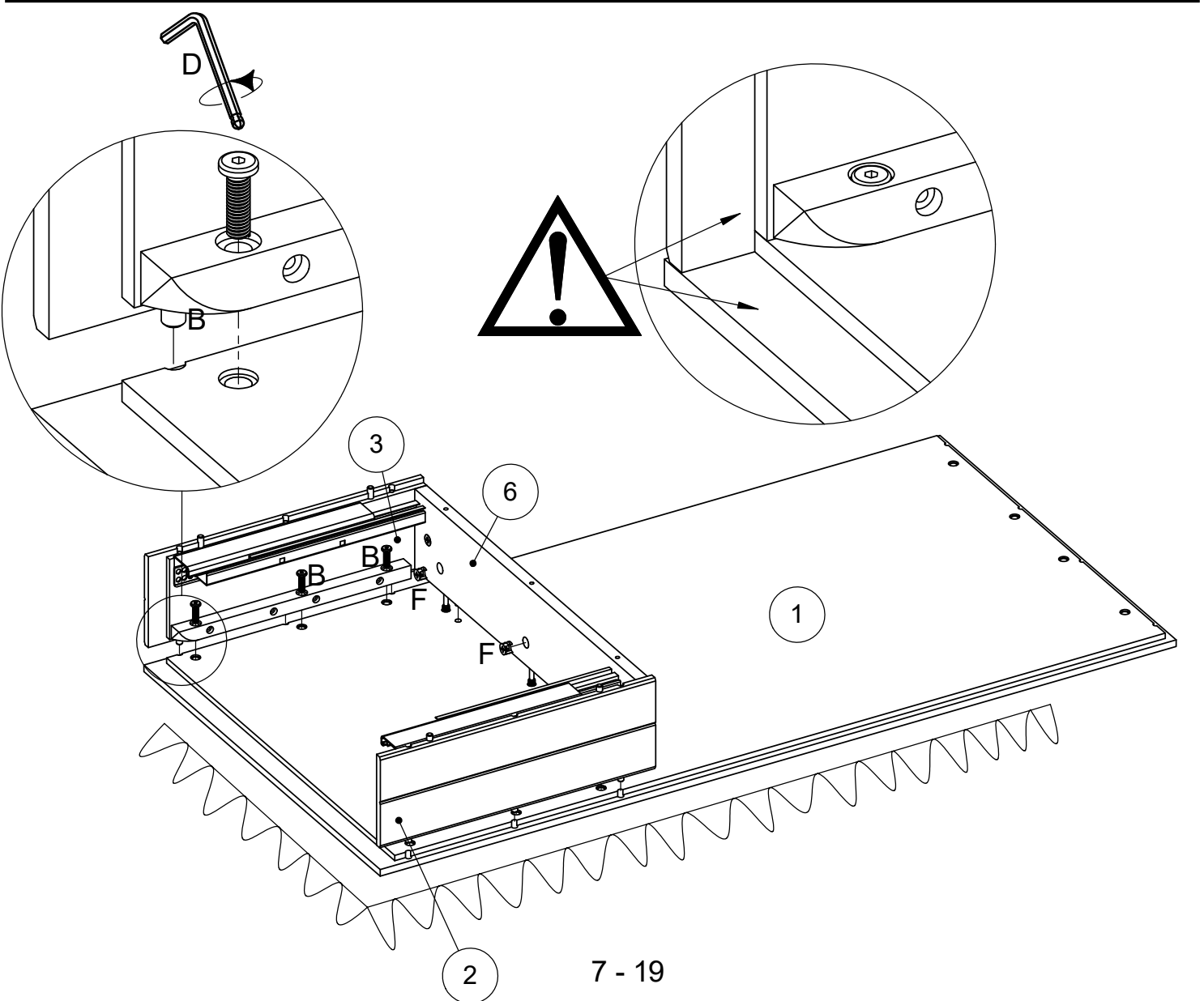

**7** A x 6  

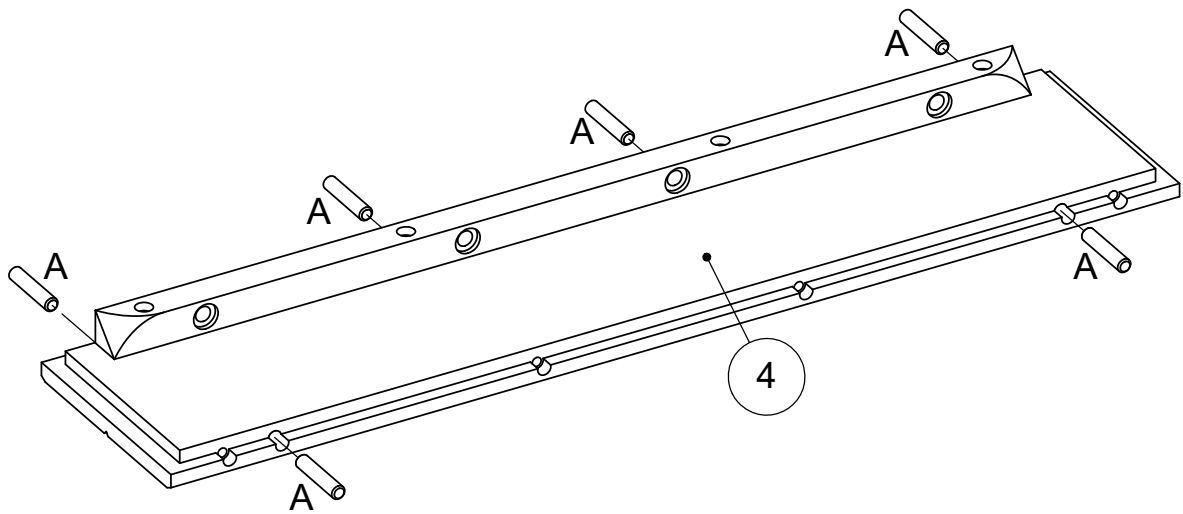

**8** B x 4 D x 1  

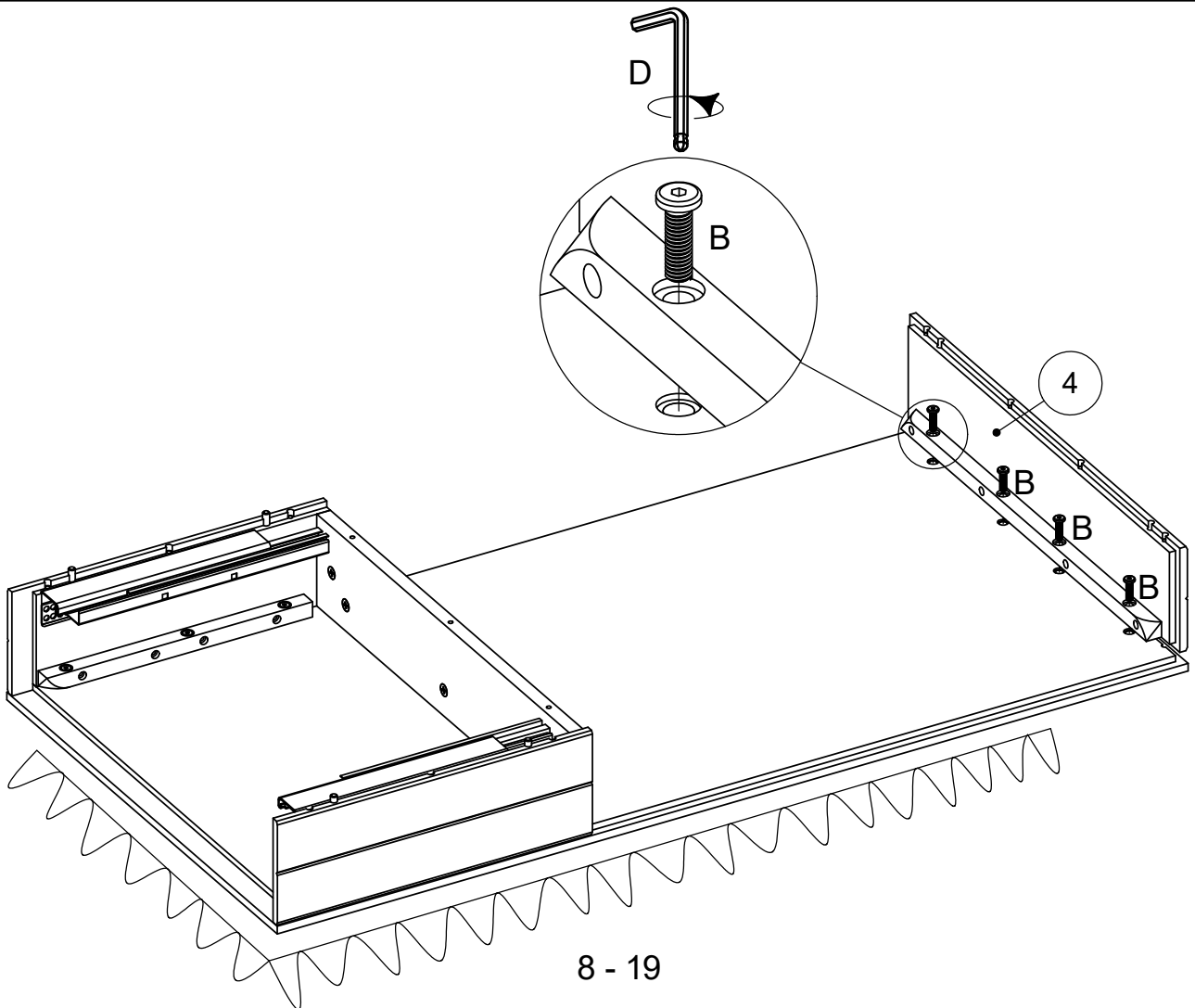



**9** C x 13 D x 1

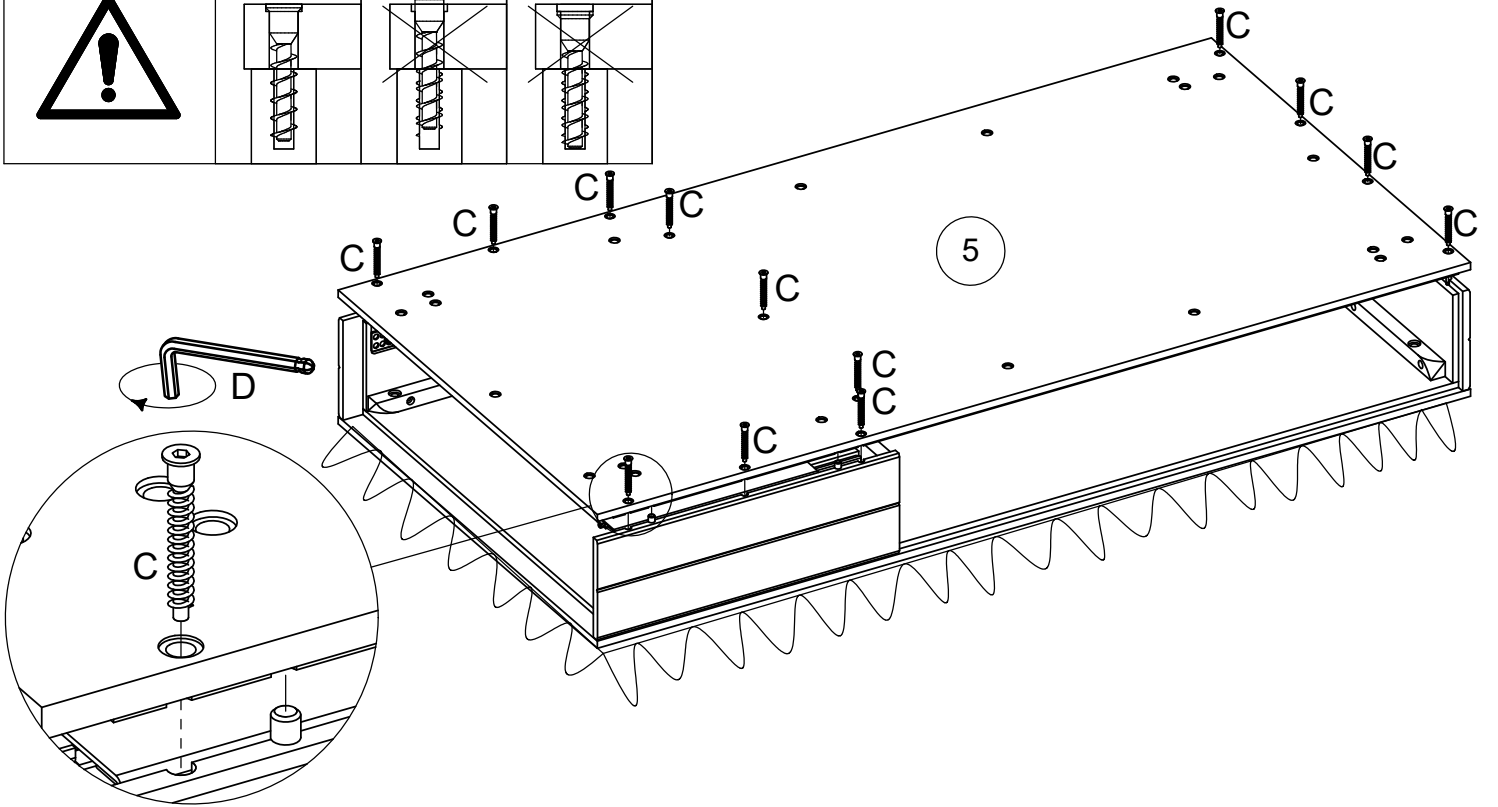
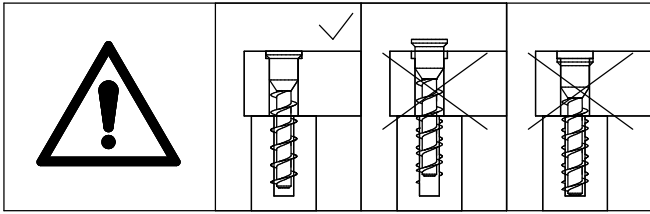

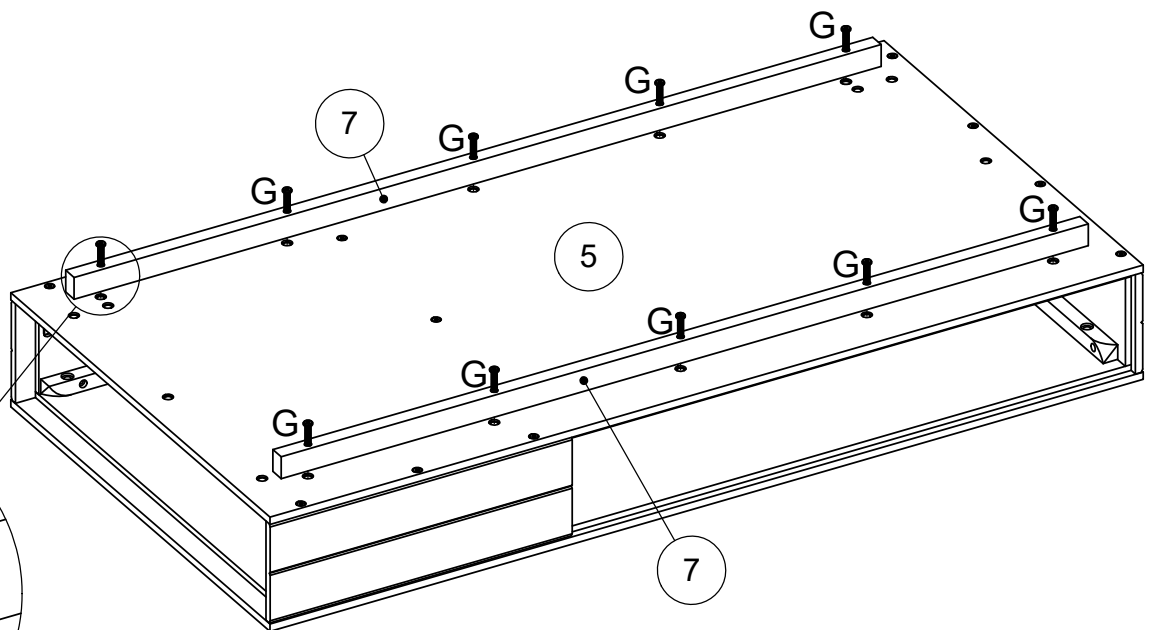
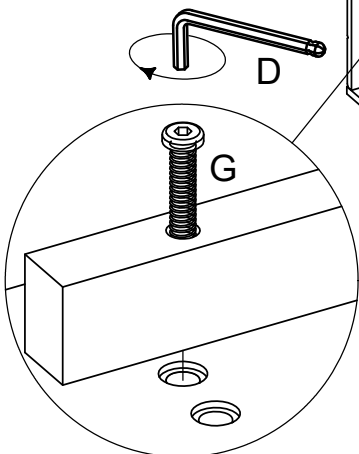
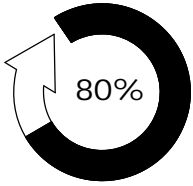

**10** G x 10 D x 1



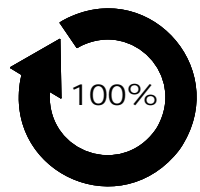
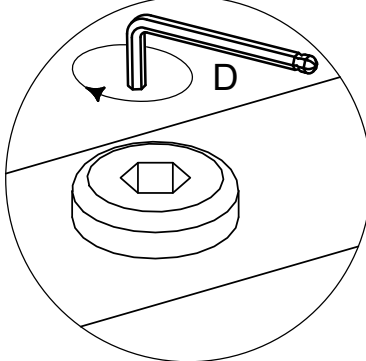
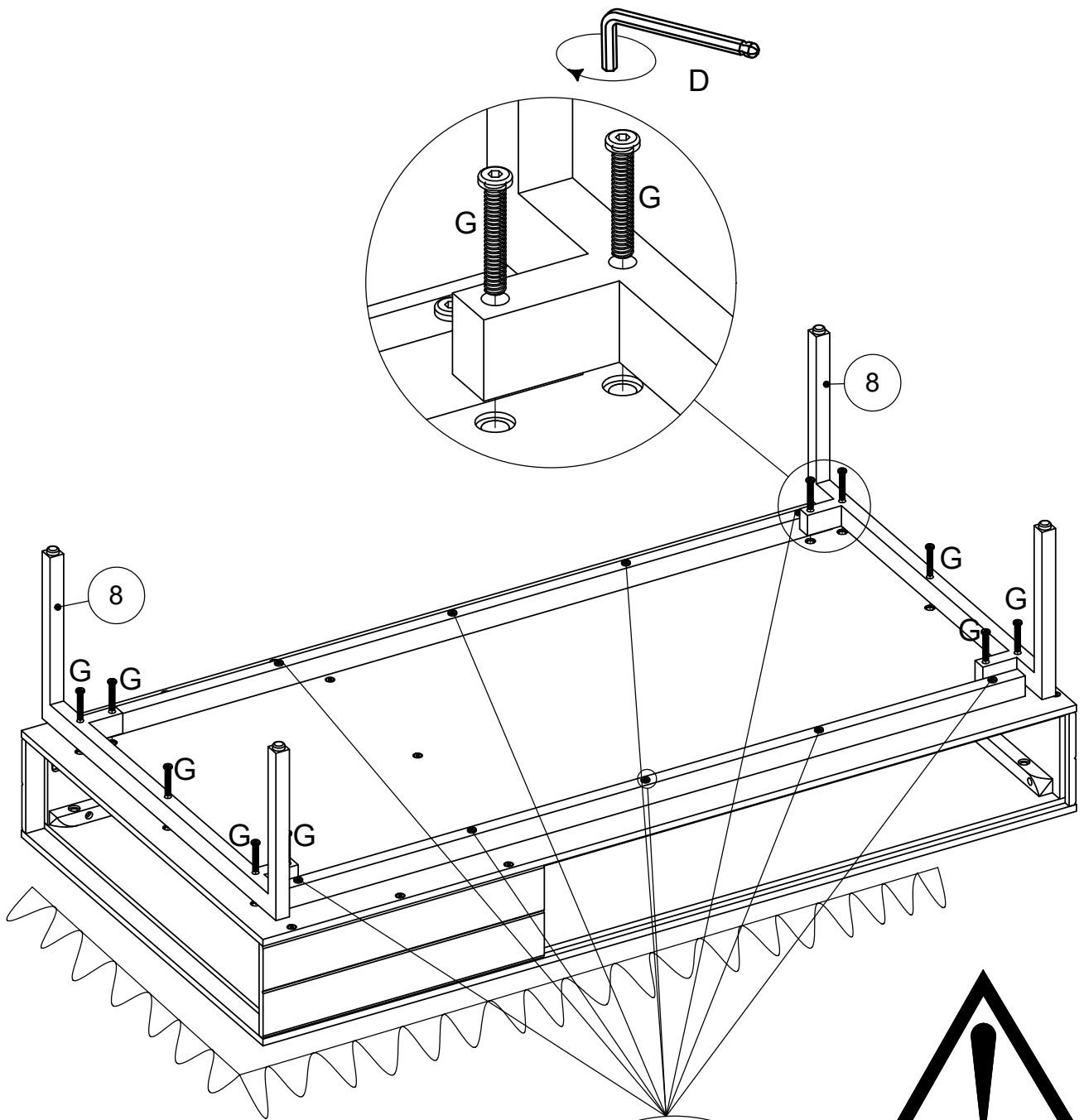

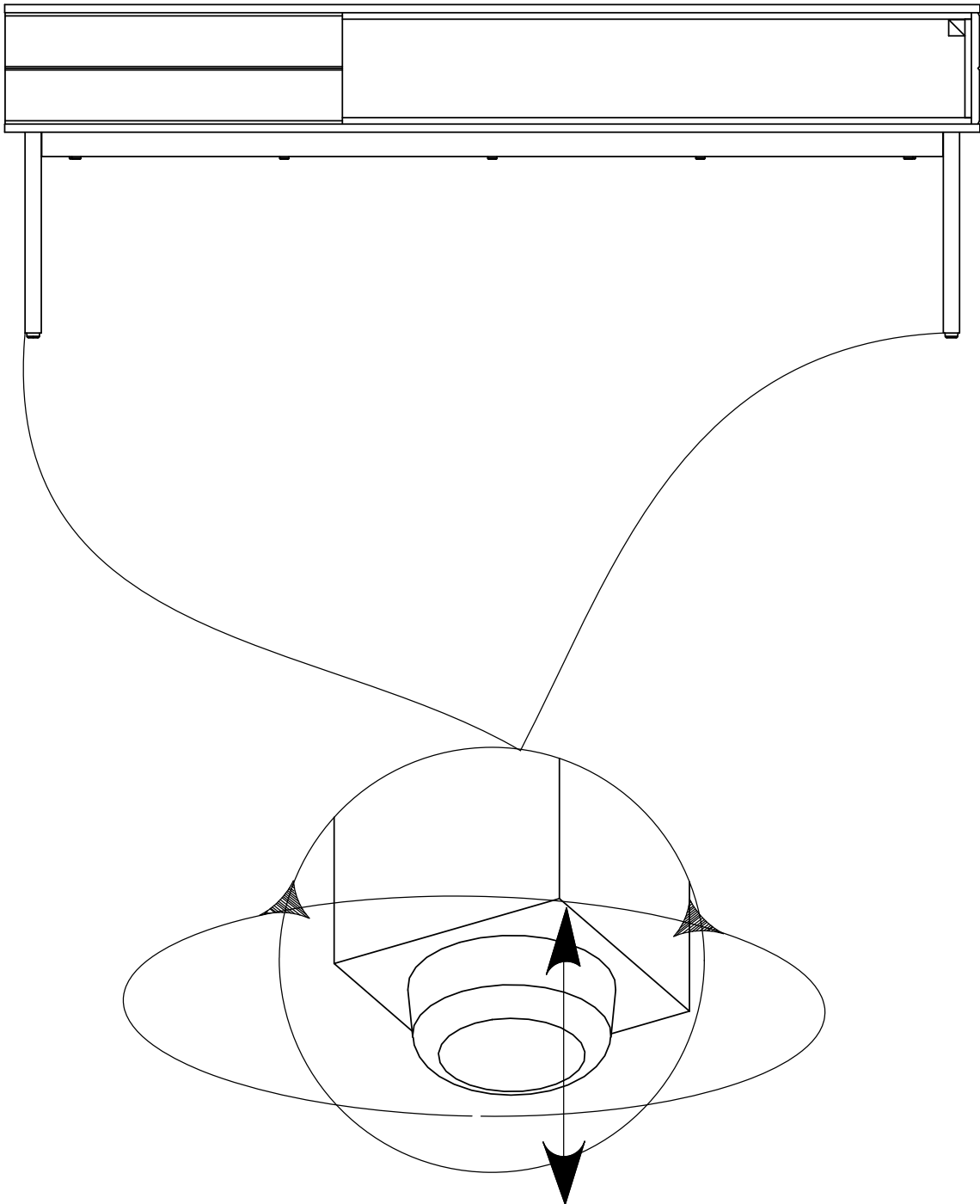
11 G x 10 D x 1



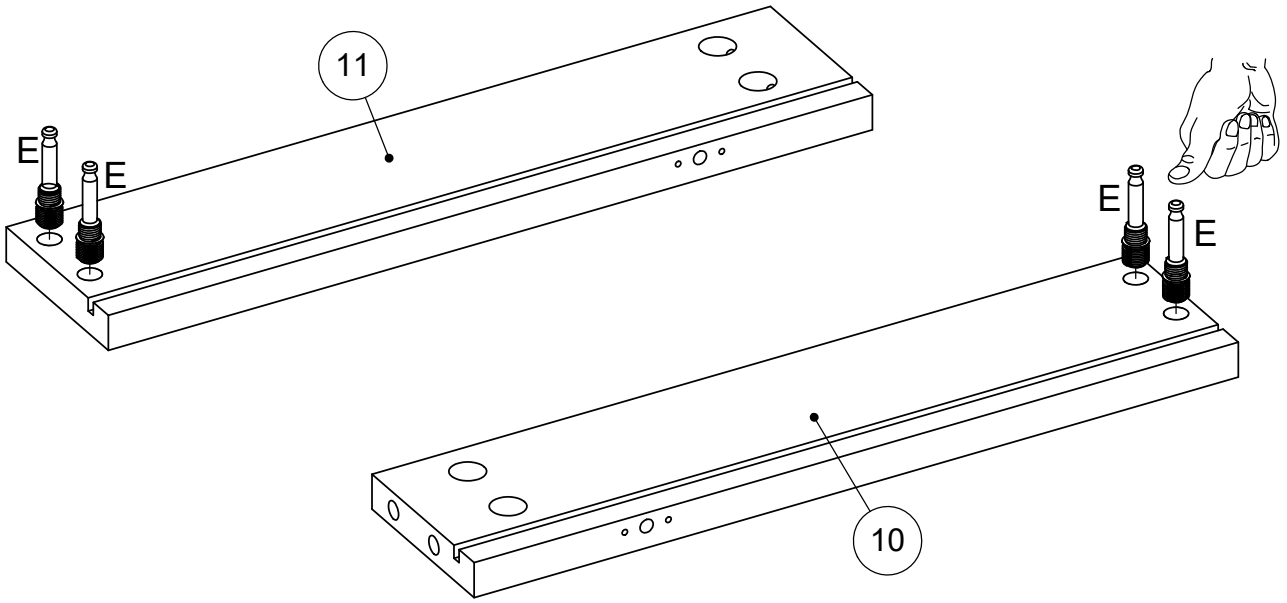

**13** E x 4



**14** F x 4

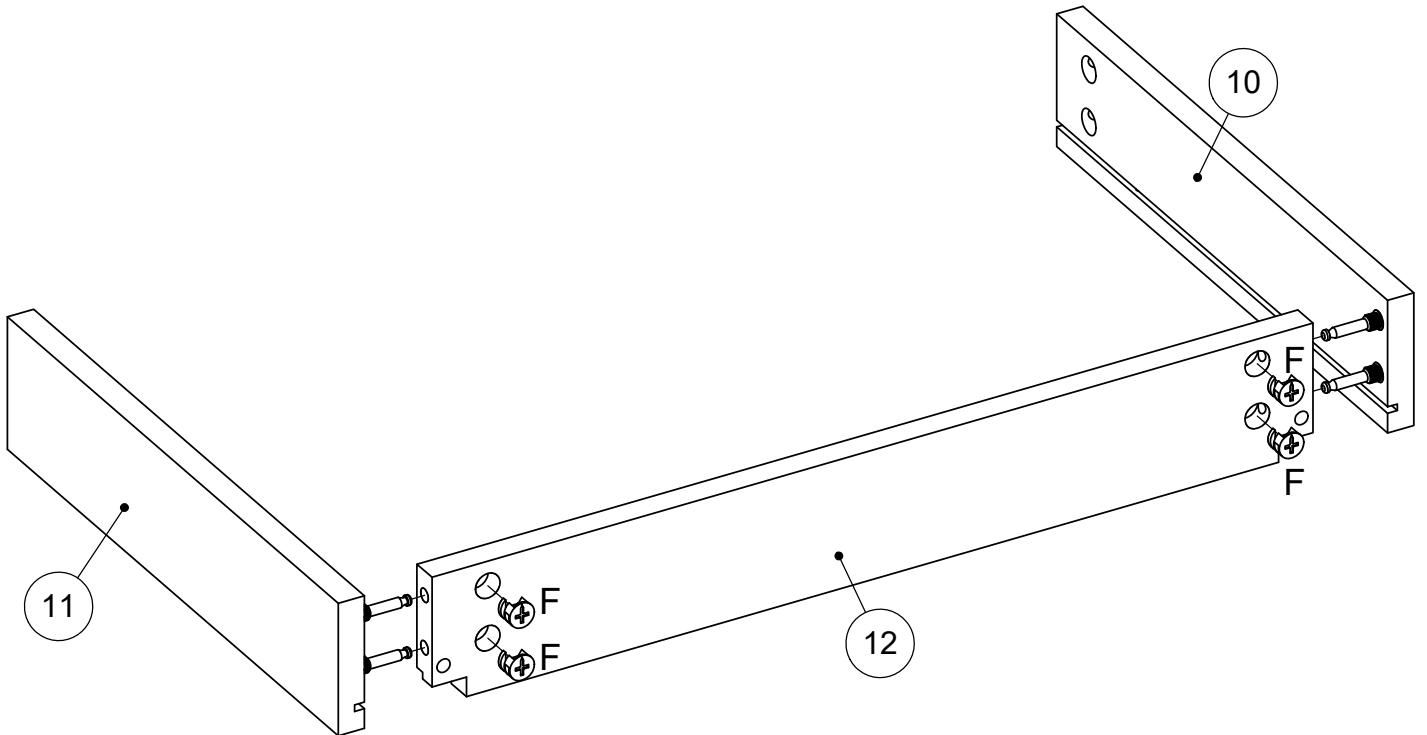
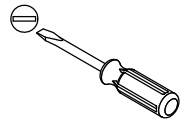

15

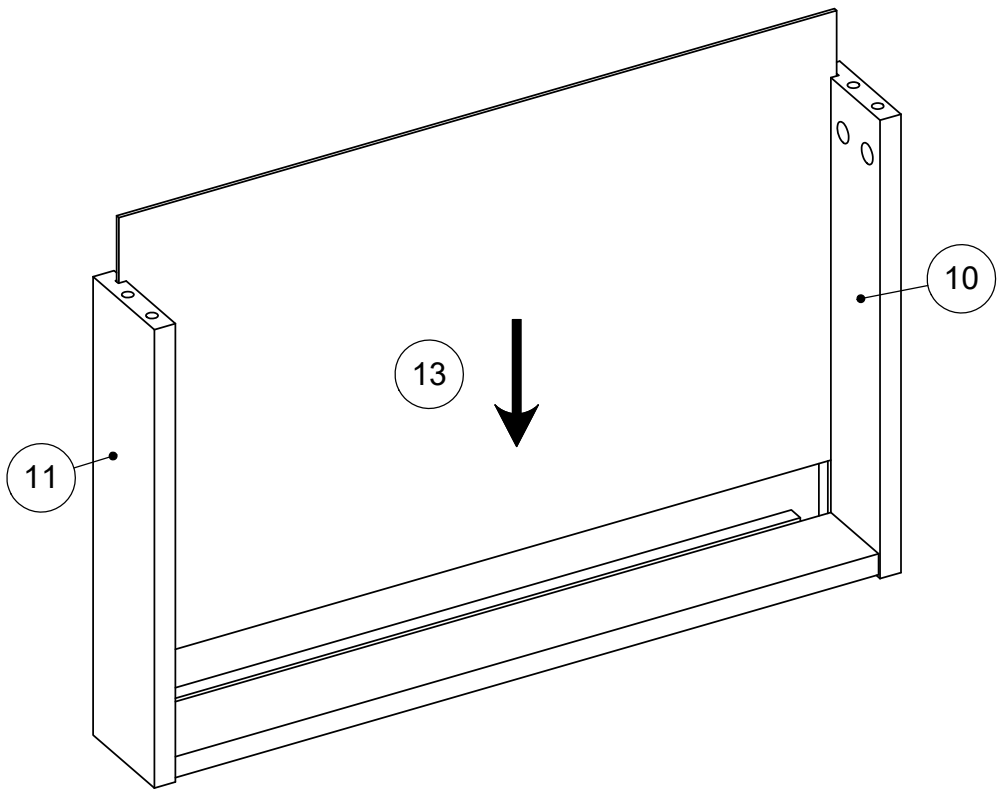

16 Ex 4

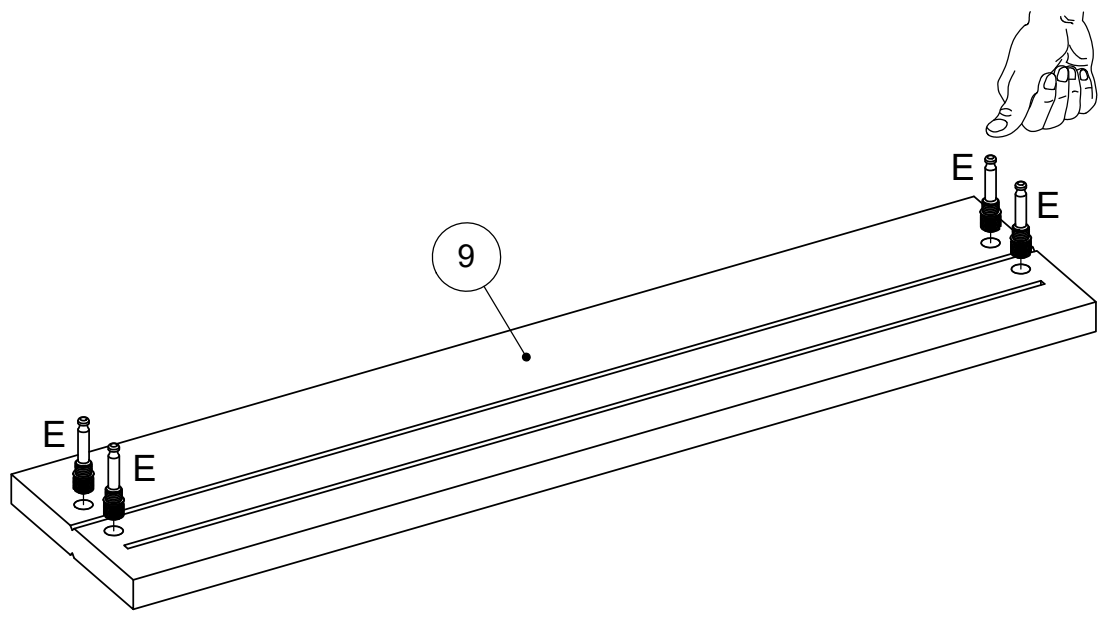

17

F x 4

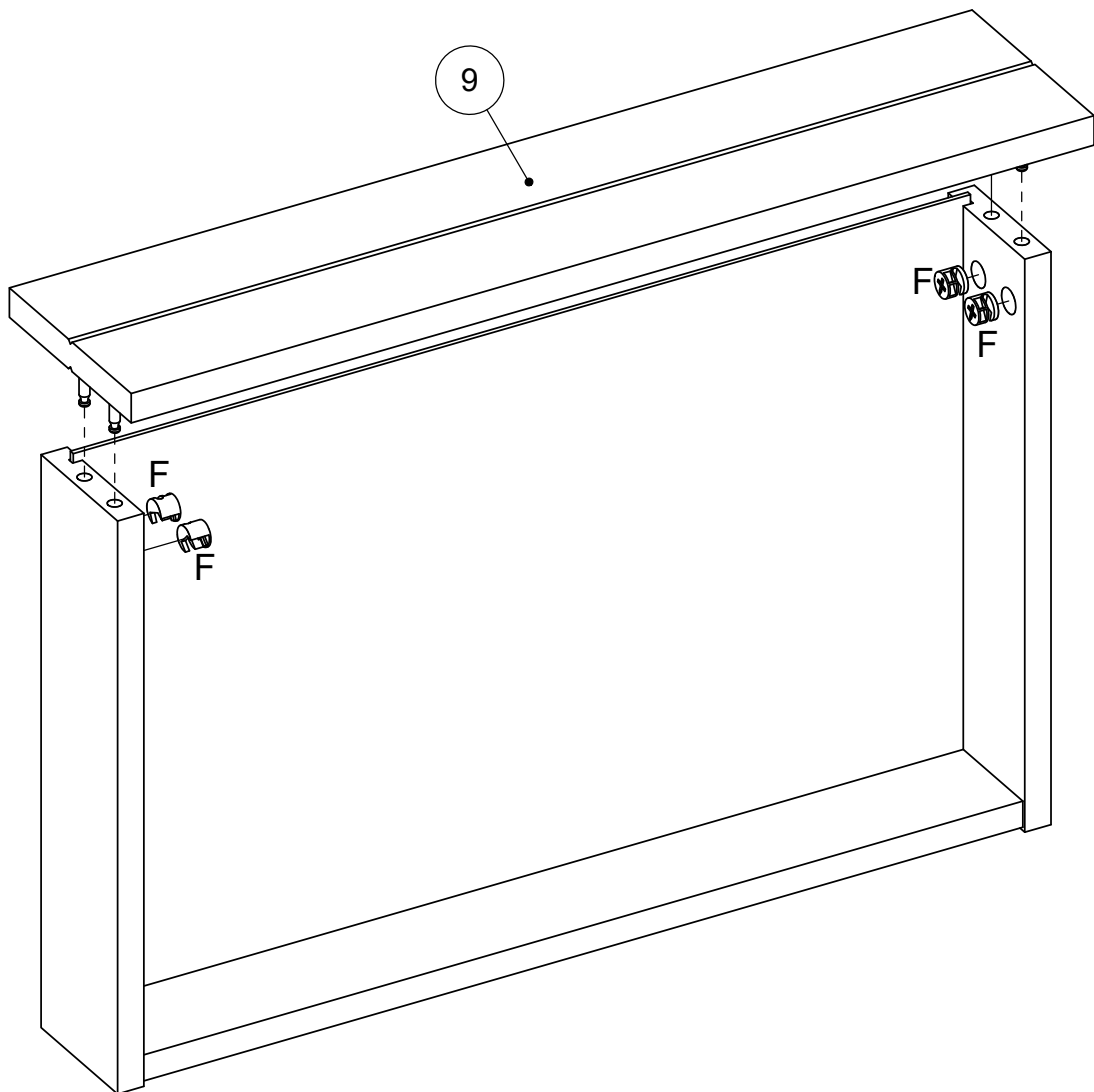
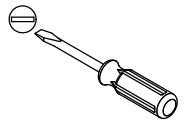

# 18

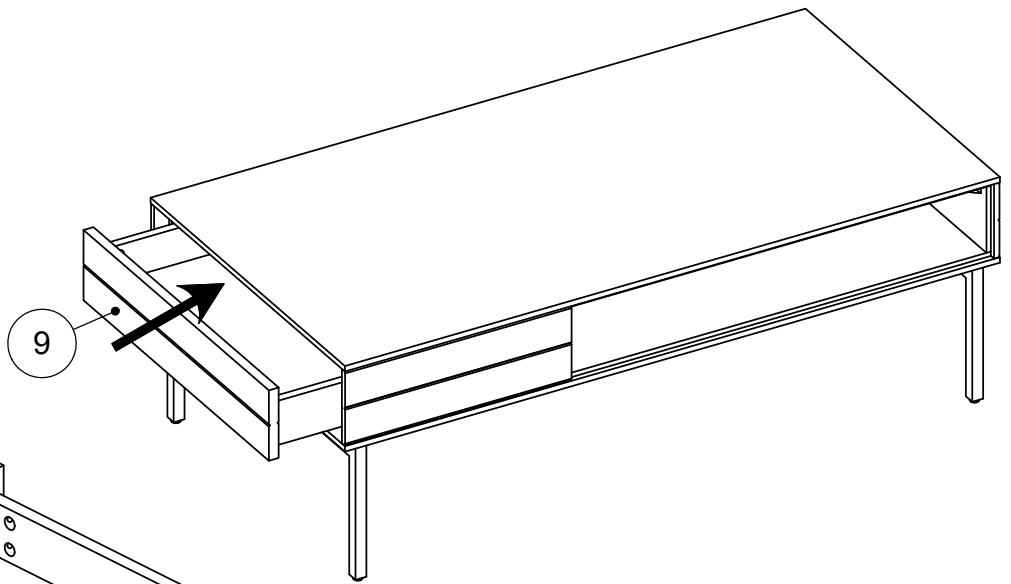

I

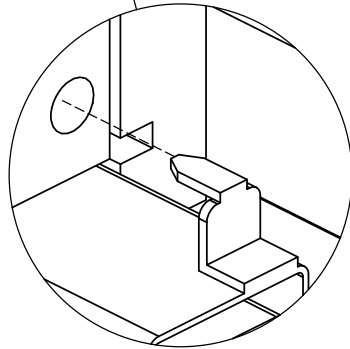
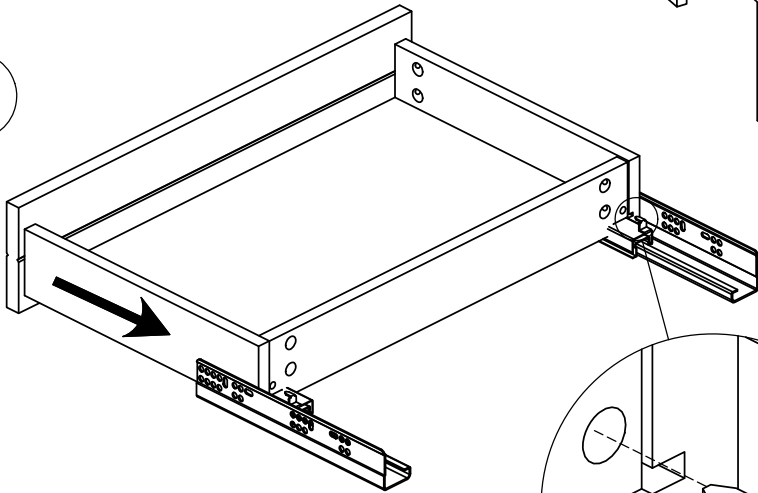

II

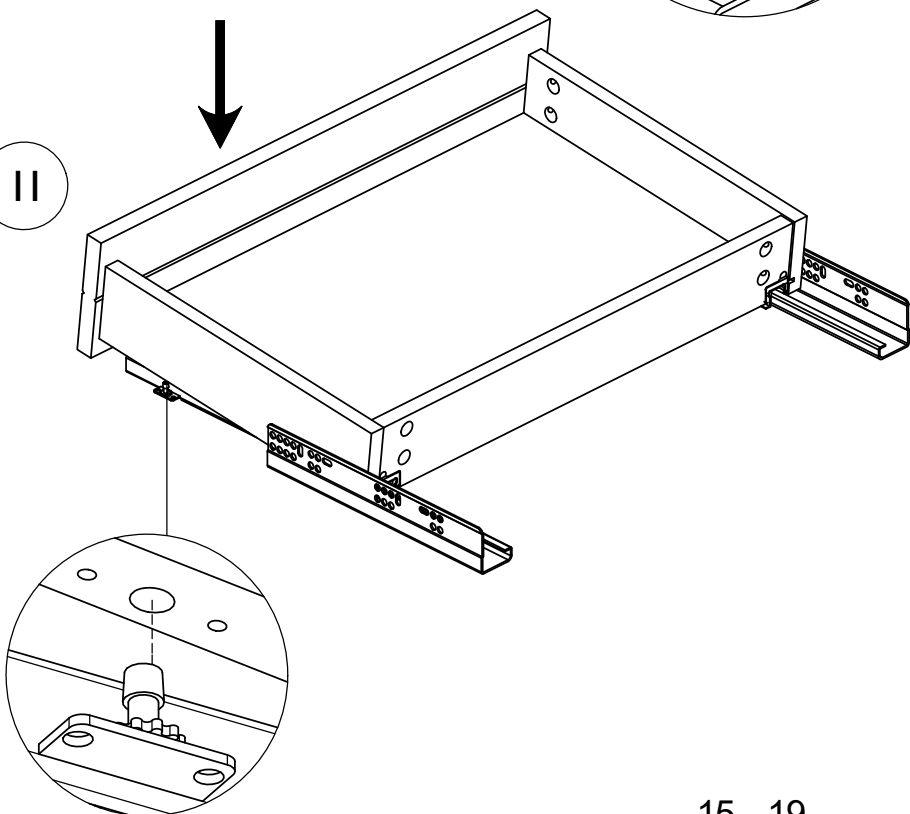

19

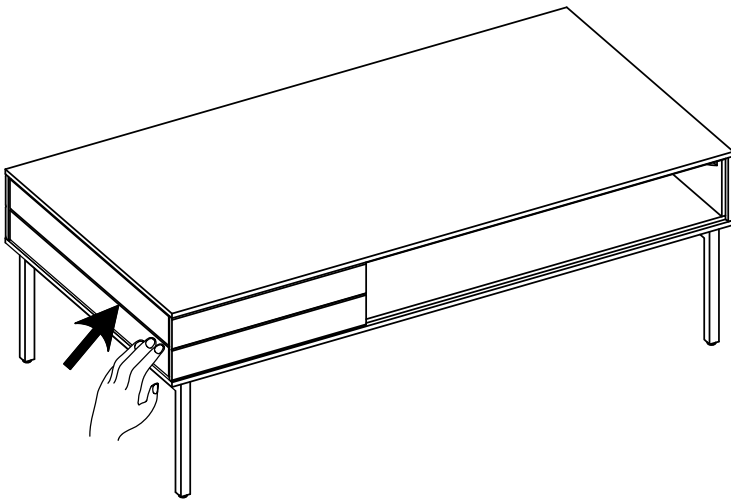
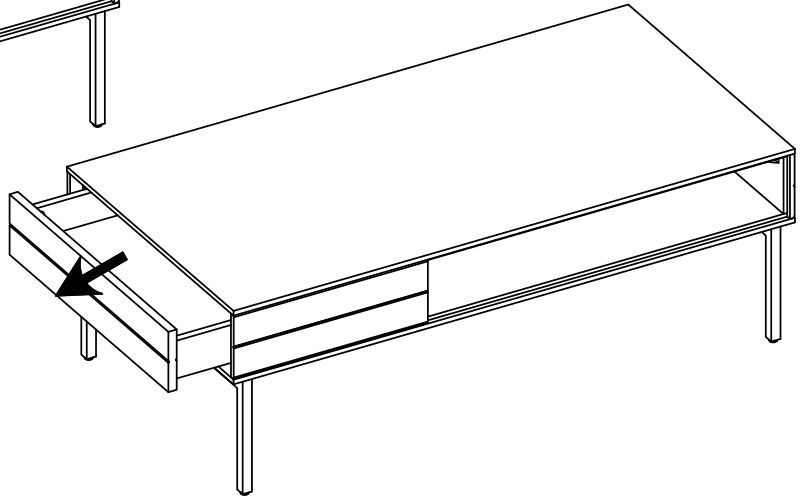
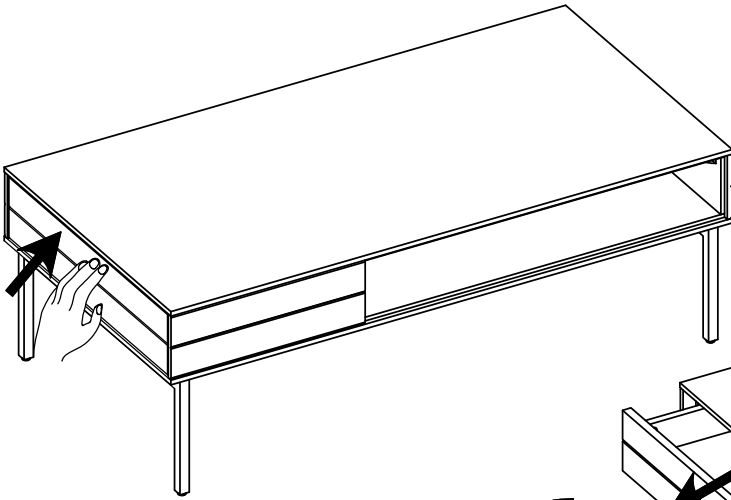



20

W x 4

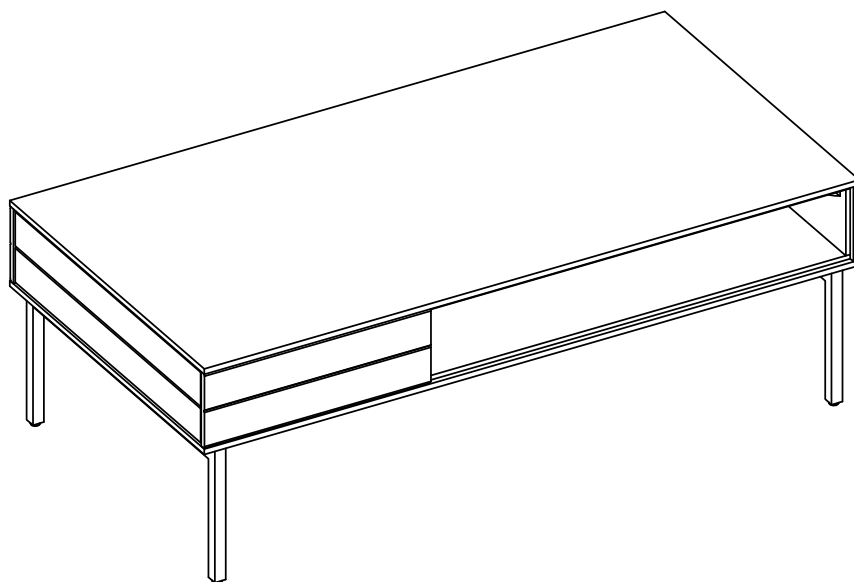
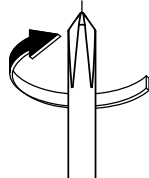
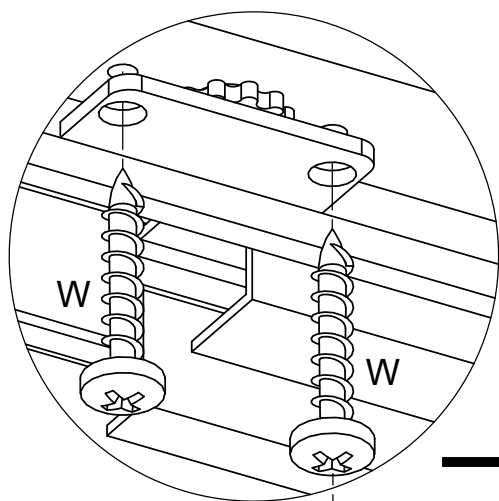
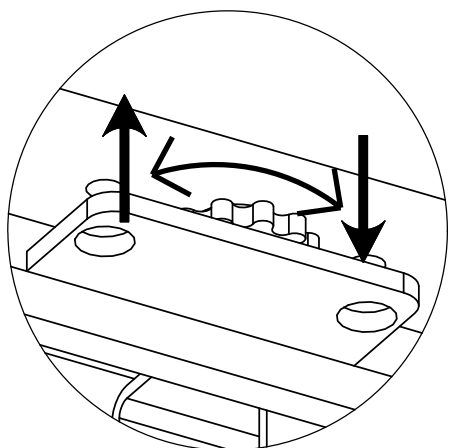
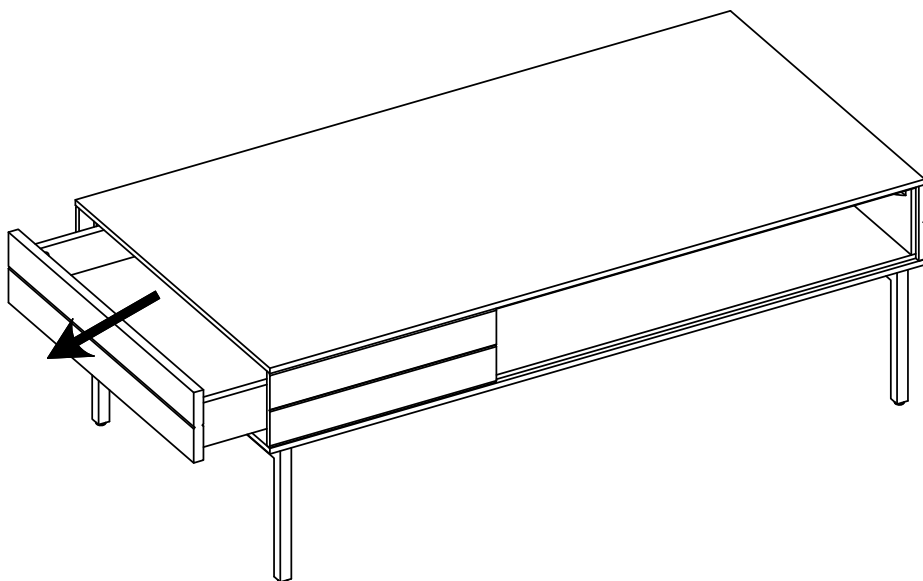
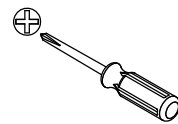
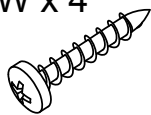

21

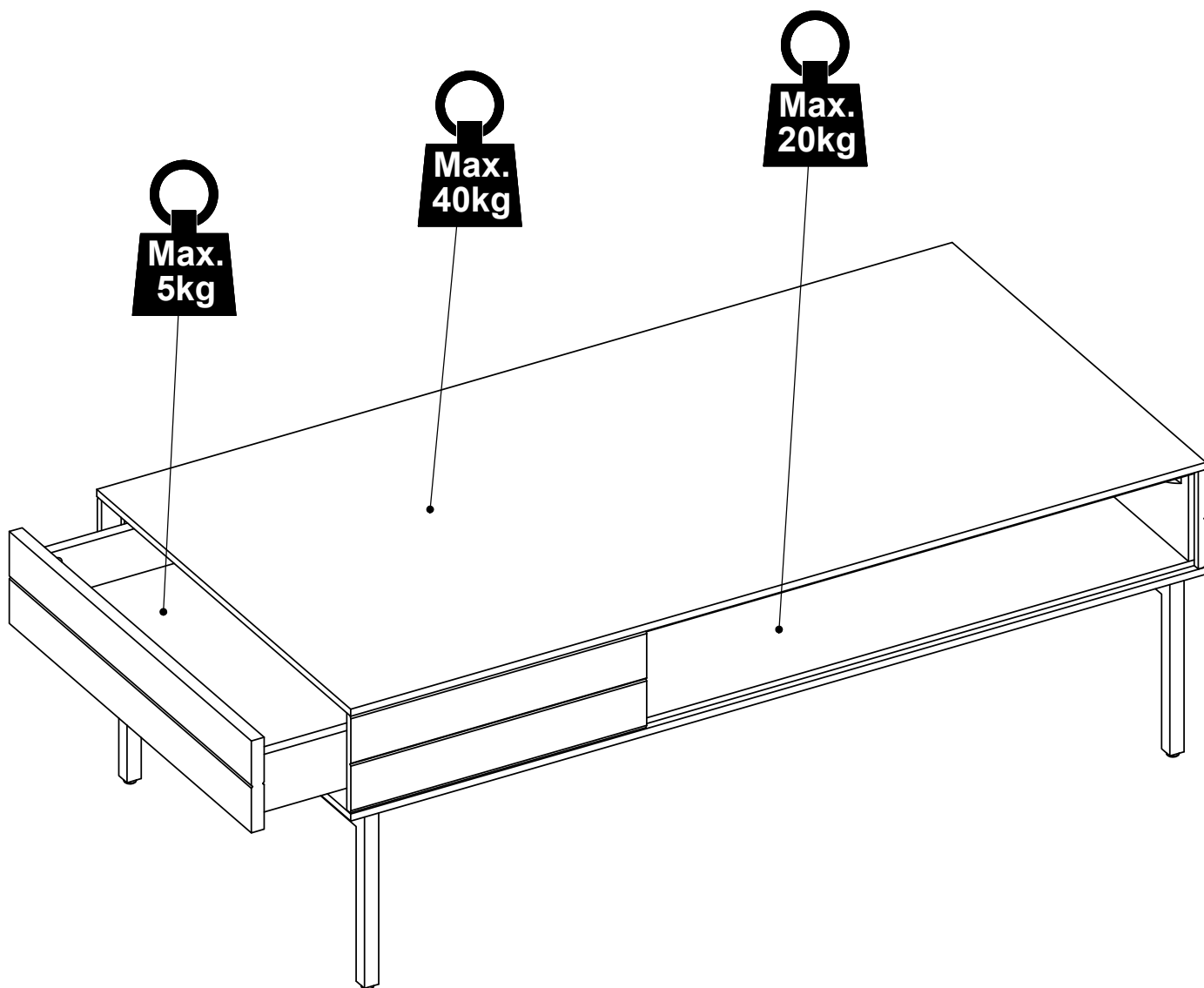



UK:

It is important that any product which is assembled using any kind of screw is re-tightened 2 weeks after assembly, and once every 3 months - in order to assure stability through-out the lifespan of the product.

DE:

Es ist wichtig, bei jedem mit Schrauben montierten Produkt diese 2 Wochen nach dem Zusammenbau sowie einmal alle 3 Monate wieder anzuziehen, um die Stabilität des Produkts über die gesamte Lebensdauer hinweg zu gewährleisten.

ES:

En el caso de los productos ensamblados, es importante volver a apretar los tornillos 2 semanas después del montaje y después cada 3 meses, para así preservar la estabilidad durante toda la vida útil del producto.

FR:

Il est important que tout produit monté à l'aide de vis soit resserré 2 semaines après son montage, puis tous les 3 mois, afin de garantir sa stabilité durant tout son cycle de vie.

DK: VIGTIGT!

Det er vigtigt, at alle produkter, der samles med alle former for skruer, efterspændes to uger efter samling samt hver tredje måned for at sikre, at produktet er stabilt i hele dets levetid.